

B003B

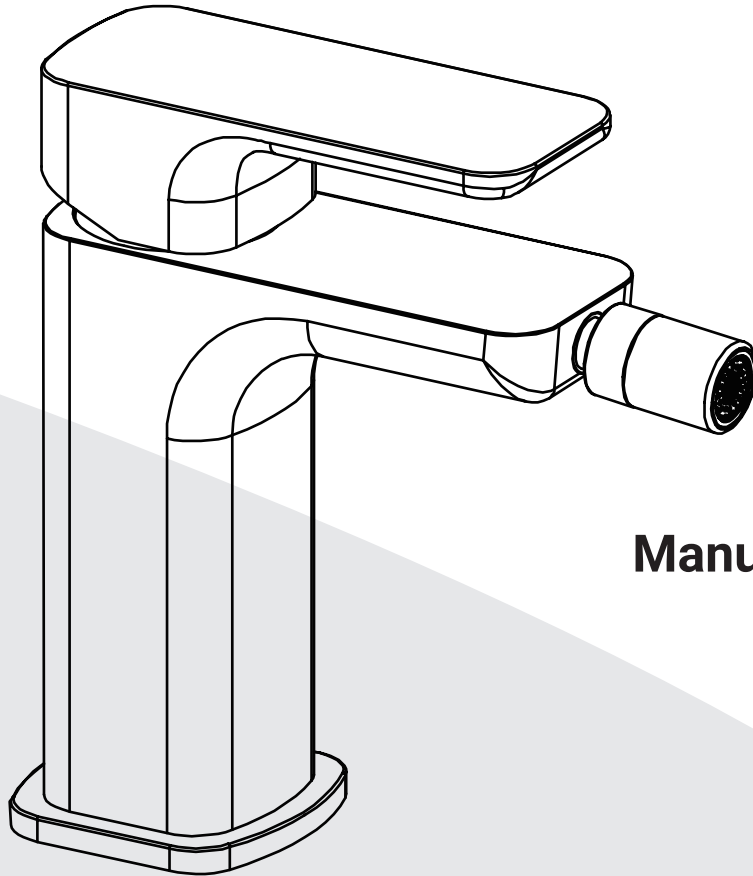

Manuale d'installazione
Installation Manual

SOG
SERIES



Bidet Miscelatore Monocomando
Bidet Single Lever Mixer

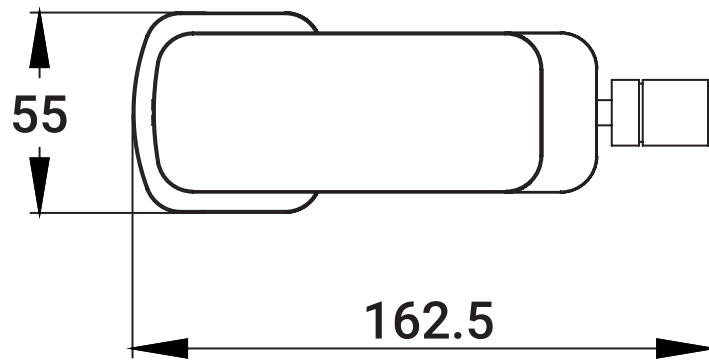
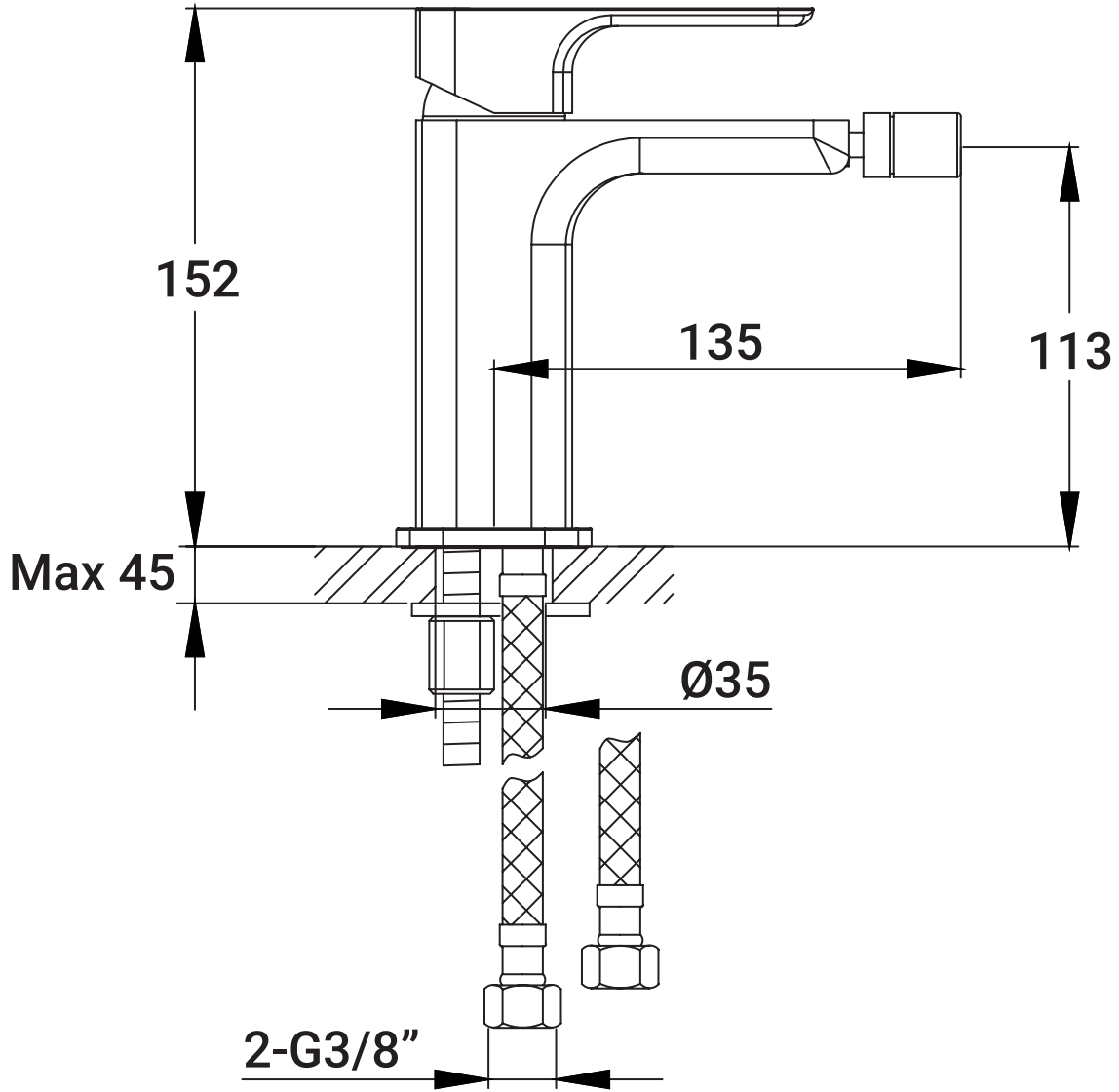

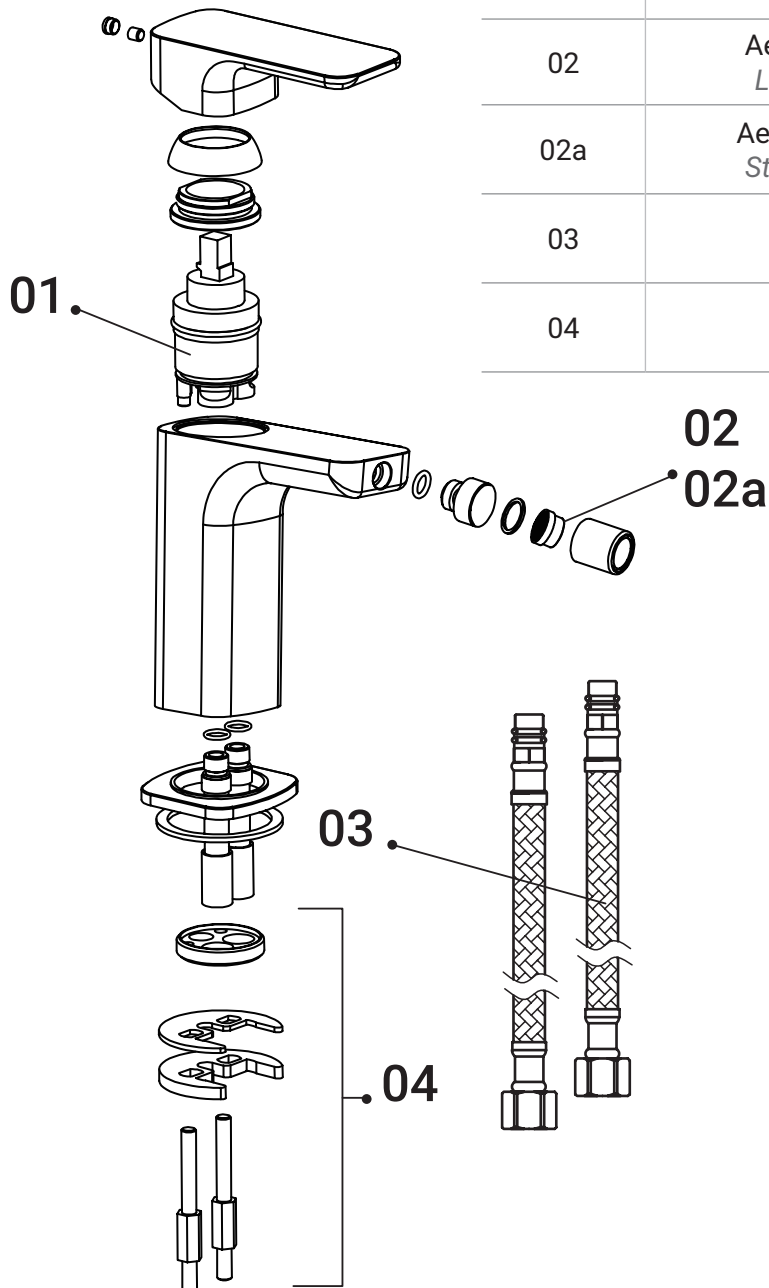

Nr.	Descrizione Description	Codice Code
01	Cartuccia Cartridge	CA0001
02	Aeratore limitato Limited Aerator	AL0001
02a	Aeratore standard Standard Aerator	AR0002
03	Flessibili Hoses	FL0001
04	Kit fissaggio Fixing kit	FIX0001



Prima dell'installazione Before Installation



Rimuovi tutto il contenuto dalla confezione e verificane la completezza.

Remove all contents from the package and check for completeness.

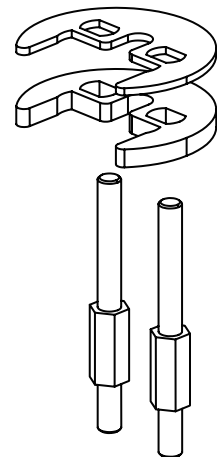
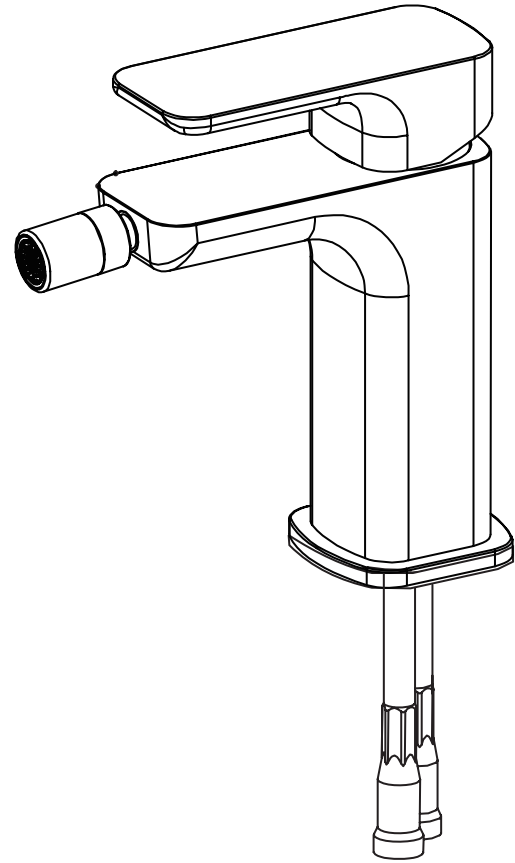

Strumenti necessari Tools you need

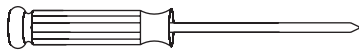

Cacciavite
Cross screwdriver



Nastro di teflon
Teflon Tape



STEP 1

Tagliare un foro di montaggio da 35 mm (1-3/8") di diametro nella posizione desiderata.

Cut a mounting hole 35mm (1-3/8") in diameter in the desired position.

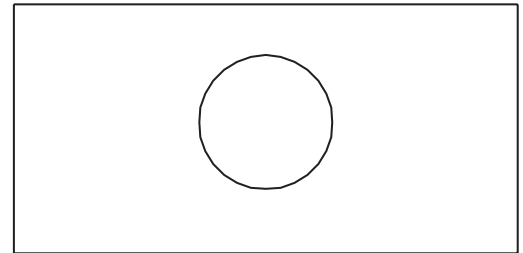
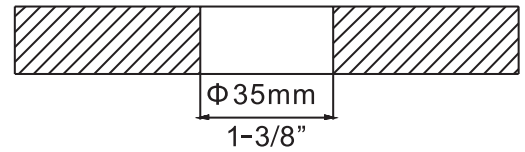

STEP 2

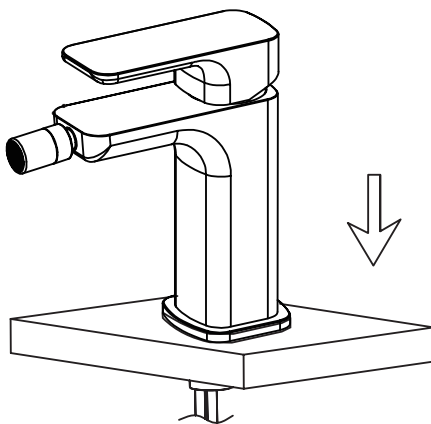

Installare il lavabo miscelatore nel centro del foro creato.

Install basin through center hole.

STEP 3

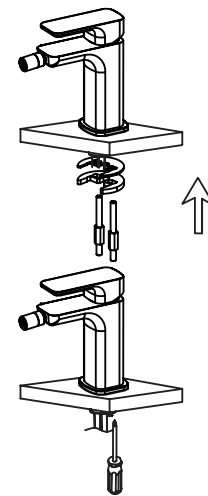

Installare la guarnizione in gomma seguita dalla rondella metallica e dal controdado, quindi fissarlo ulteriormente stringendo le viti di fissaggio con un cacciavite.

Install the rubber washer followed by the metal washer and lock-nut. Hand tighten then tighten further using a screw driver to tighten lock-nut screws.



STEP 4

Avvitare e stringere a mano i tubi flessibili del caldo e del freddo al lavabo miscelatore. Non usare una chiave per stringere i tubi per non danneggiare il tubo e/o le filettature del tubo.

Screw and hand tighten the hot and cold flexible hoses to the basin inlet tubes. Do not use a wrench to tighten hoses as this may damage the hose and/or the hose's threads.

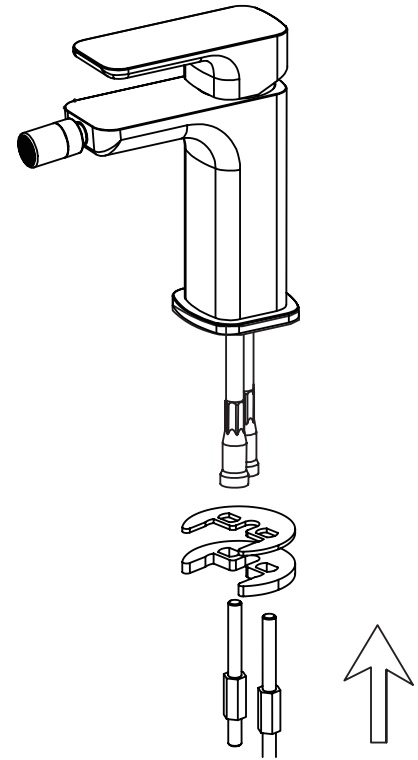

STEP 5

Collegare il tubo flessibile alla rete idrica.

Connect flexible hose to water supply.

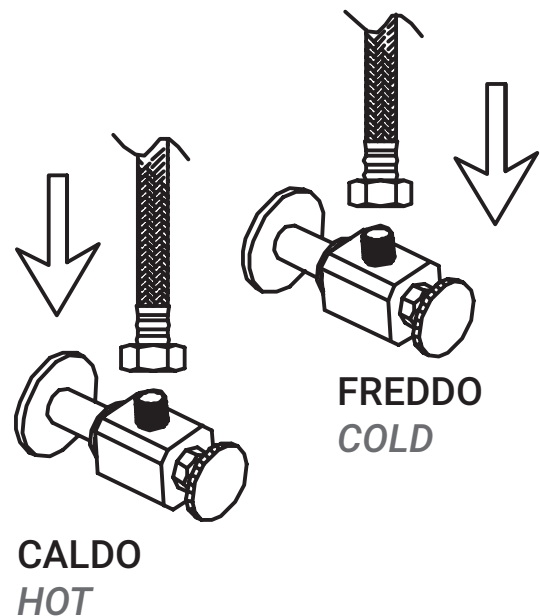



STEP 6

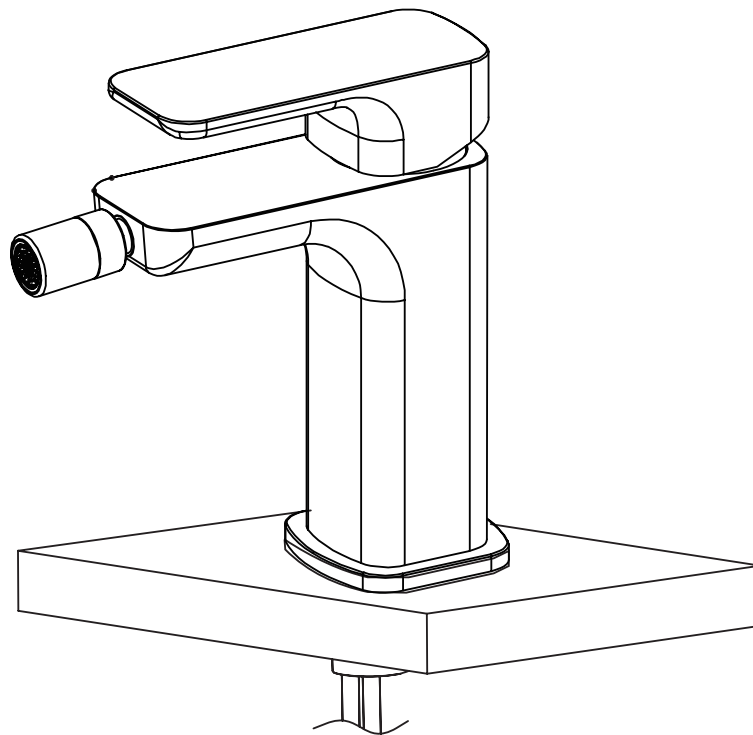

Rimuovere l'aeratore e aprire il miscelatore del rubinetto per circa 1 minuto per togliere eventuali detriti dal miscelatore e dalle linee di alimentazione. Girare il miscelatore del rubinetto del lavabo chiudere l'acqua e reinstallare l'aeratore.

Remove the aerator and turn off tap mixer for 1-minute to flush debris from basin and feed lines. Turn off tap mixer and re-install aerator.

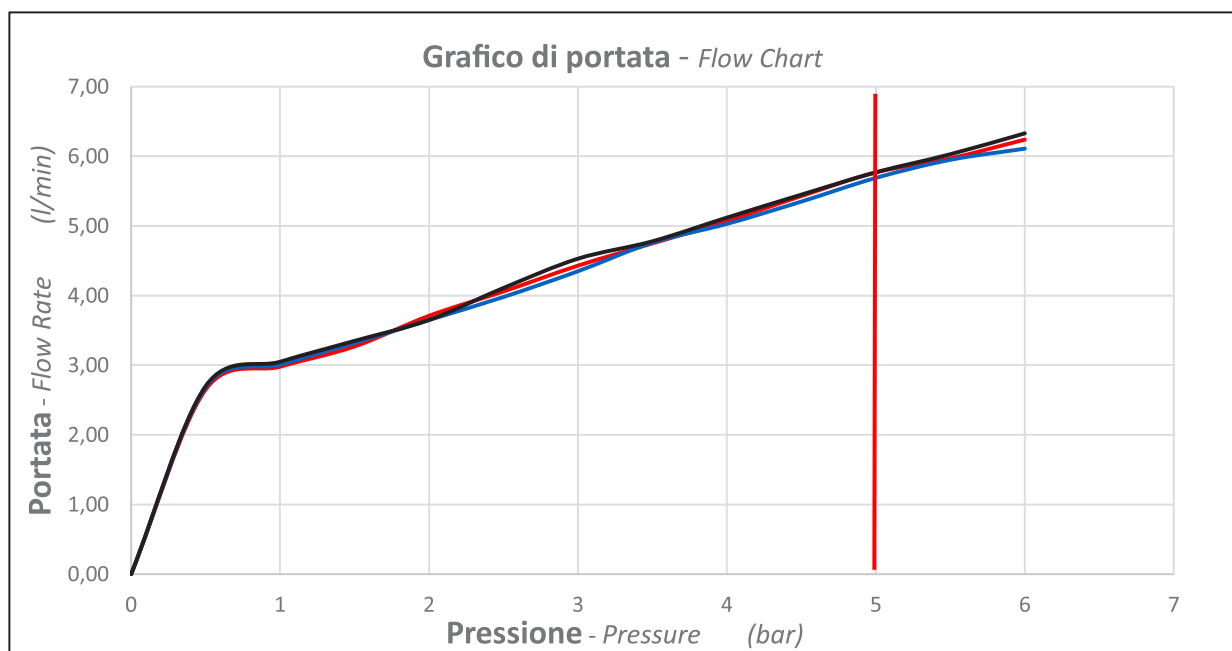

Aeratore limitato
Limited aerator

Misurazione (Measure)	Pressione (Pressure) (bar)	Portata Calda (Hot Flow Rate) (l/min)	Portata Fredda (Cold Flow Rate) (l/min)	Portata Miscelata (Mix Flow Rate) (l/min)
1	0	0,00	0,00	0,00
2	0,5	2,65	2,68	2,70
3	1	2,98	3,01	3,05
4	1,5	3,27	3,32	3,35
5	2	3,71	3,65	3,65
6	2,5	4,06	3,98	4,11
7	3	4,43	4,35	4,53
8	3,5	4,75	4,76	4,78
9	4	5,07	5,03	5,12
10	4,5	5,43	5,35	5,45
11	5	5,77	5,69	5,77
12	5,5	5,97	5,95	6,03
13	6	6,24	6,11	6,33

Massima Pressione Operativa (MPO): 5 bar
Maximum Operating Pressure (MOP): 5 bar
Test eseguito con flessibili originali
(Test performed with original hoses)

Non superare la pressione di 5 bar (linea rossa)
Do not exceed the pressure of 5 bar (red line)

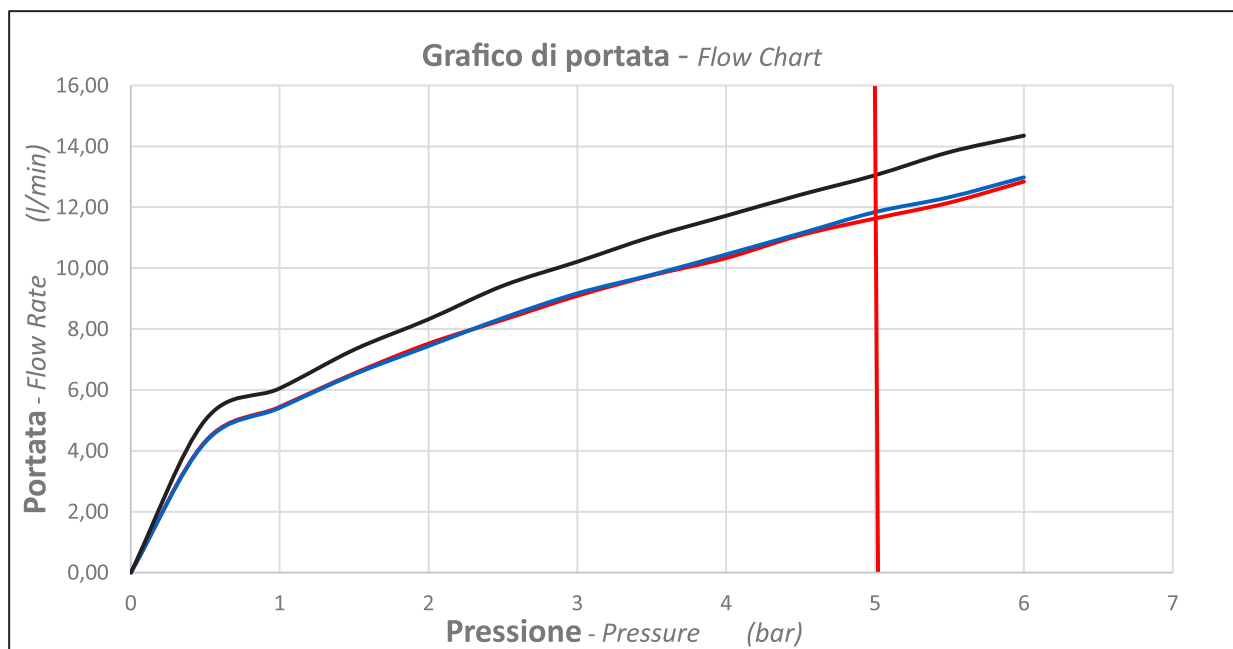
Aeratore non limitato
Not limited aerator

Misurazione (Measure)	Pressione (Pressure) (bar)	Portata Calda (Hot Flow Rate) (l/min)	Portata Fredda (Cold Flow Rate) (l/min)	Portata Miscelata (Mix Flow Rate) (l/min)
1	0	0,00	0,00	0,00
2	0,5	4,31	4,28	5,01
3	1	5,44	5,41	6,05
4	1,5	6,54	6,51	7,32
5	2	7,52	7,44	8,32
6	2,5	8,30	8,36	9,42
7	3	9,09	9,17	10,21
8	3,5	9,76	9,78	11,03
9	4	10,33	10,45	11,72
10	4,5	11,08	11,14	12,41
11	5	11,63	11,84	13,05
12	5,5	12,15	12,33	13,81
13	6	12,84	12,98	14,35

Massima Pressione Operativa (MPO): 5 bar
Maximum Operating Pressure (MOP): 5 bar
Test eseguito con flessibili originali
(Test performed with original hoses)

Non superare la pressione di 5 bar (linea rossa)
Do not exceed the pressure of 5 bar (red line)



Non utilizzare, per la pulizia, in nessun caso acidi, solventi, candeggina, ammoniaca o prodotti contenenti acidi e spugne o spazzole con effetto abrasivo.

Never use acids, solvents, bleach, ammonia or products containing acids and sponges or brushes with an abrasive effect for cleaning.



Per un corretto mantenimento dei prodotti si consiglia una pulizia periodica attraverso detergenti neutri o acqua e sapone.

For correct maintenance of the products, periodic cleaning is recommended using neutral detergents or soap and water.



Per evitare la formazione di depositi calcarei sciacquare sempre le superfici dopo lavaggio con abbondante acqua e asciugare accuratamente con un panno morbido.

To avoid the formation of limescale deposits, always rinse the surfaces after washing with plenty of water and dry carefully with a soft cloth.



Per un corretto mantenimento del getto di acqua pulire periodicamente l'aeratore immergendolo, dopo averlo smontato in soluzione di acqua e aceto.

For correct maintenance of the water jet, periodically clean the aerator by immersing it, after having disassembled it, in a solution of water and vinegar.